

Affordable Automation
for Welding, Cutting and
Semi-Automatic Processes

CARRIAGES

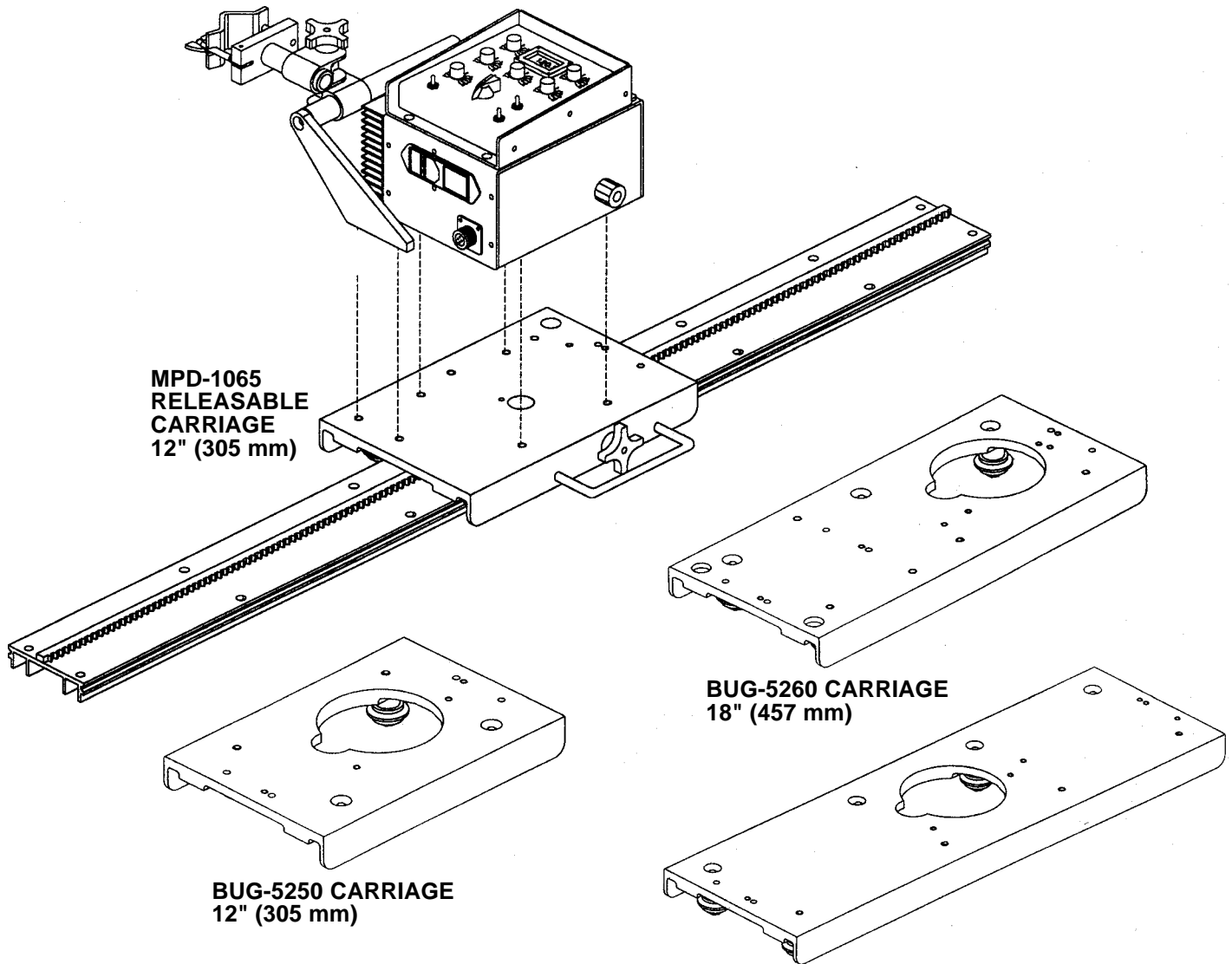

The BUG-O Systems Carriages are made of high-strength, lightweight aluminum alloy. The carriage wheels ride in opposed recessed grooves or ways, in the Aluminum Rigid Rails, locking the carriage to the rail in all positions. The pinion from the drive unit goes through the carriage and engages the rack on the rail, providing a positive drive. One set of wheels on each carriage is adjustable to allow for smooth accurate travel. The wheels contain permanently lubricated sealed bearings. All steel components are plated to resist corrosion.

PATENTS WORLDWIDE



BUG-O SYSTEMS
A DIVISION OF WELD TOOLING CORPORATION



3001 WEST CARSON STREET PITTSBURGH, PENNSYLVANIA USA 15204-1899
PHONE: 1-800-245-3186 <http://www.bugo.com> TELEFAX: 1-412-331-0383



CARRIAGES

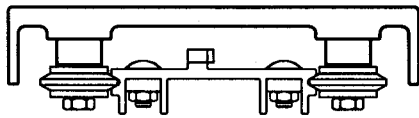

Close-up showing a front view of a carriage mounted on Aluminum Rail.

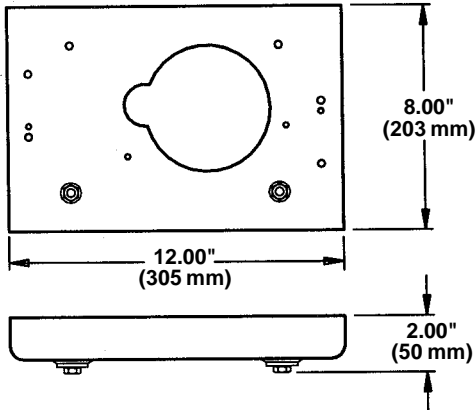

BUG-5250 CARRIAGE 12" (305 mm)
Net Weight: 5 lbs. (2.26 kg)
Shipping Weight: 7 lbs. (3.17 kg)

- Mounts a DC IV Drive Unit
- 100 lb (45 kg) carrying capacity.

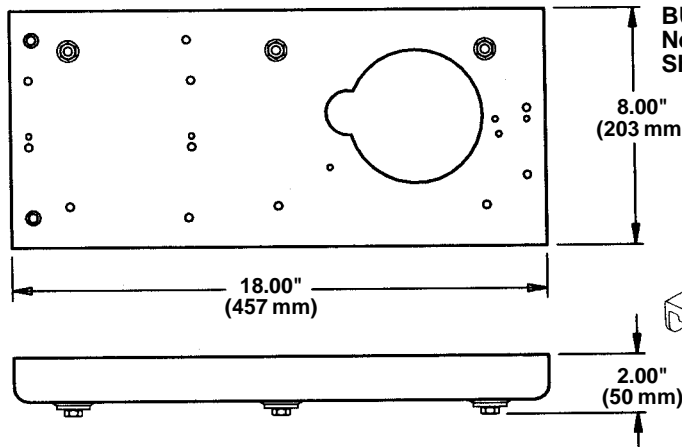
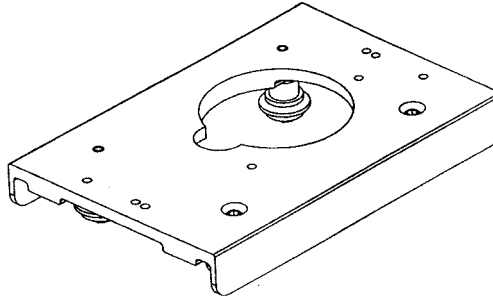

BUG-5260 CARRIAGE 18" (457 mm)
Net Weight: 8 lbs. (3.62 kg)
Shipping Weight: 10 lbs. (4.53 kg)

- Mounts a DC IV Drive Unit.
- 100 lb (45 kg) carrying capacity with a DC IV mounted on the carriage.
- 150 lb (67.5 kg) carrying capacity when used as a trailer.
- Longer deck to mount accessories, wire feeder, etc.

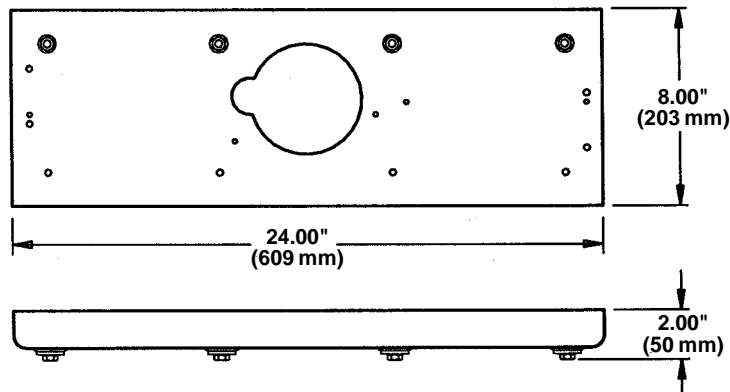
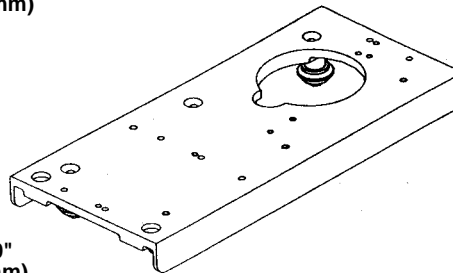

BUG-2790 CARRIAGE 24" (609 mm)
Net Weight: 11 lbs. (5 kg)
Shipping Weight: 15 lbs. (6.80 kg)

- Mounts a DC IV Drive Unit.
- 100 lb (45 kg) carrying capacity with a DC IV mounted on the carriage.
- 200 lb (90 kg) carrying capacity when used as a trailer.
- Longer deck to mount accessories, wire feeder, etc.

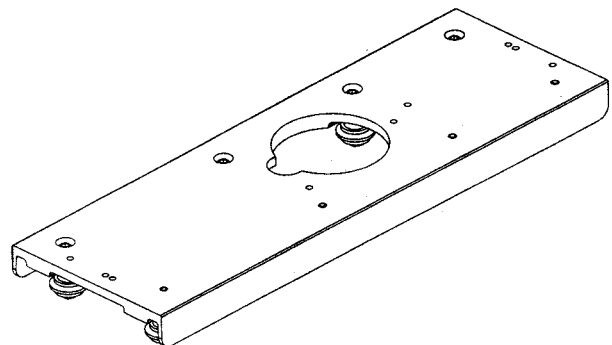



CARRIAGES

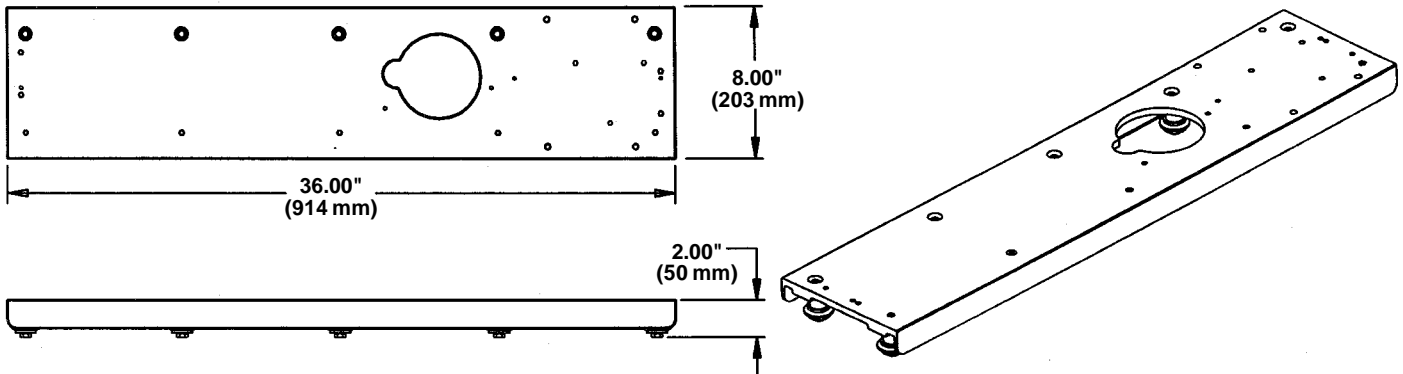

BUG-2785 CARRIAGE

36" (914 mm)

Net Weight: 16.5 lbs. (7.50 kg)
Shipping Weight: 23.0 lbs. (10.44 kg)

- Mounts a DC IV Drive Unit.
- 200 lb (90 kg) carrying capacity when used as a trailer.
- 100 lb (45 kg) carrying capacity with a DC IV mounted on the carriage.
- Longer deck to mount accessories, wire feeder, etc.

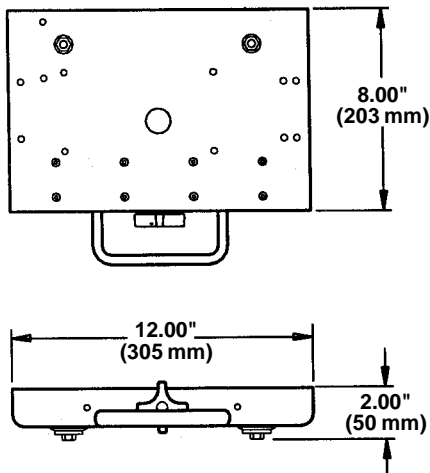

MPD-1065 Releasable Carriage

Net Weight: 7.75 lbs. (2.52 kg)
Shipping Weight: 9lbs. (4.09 kg)

- Mounts a DC IV Drive Unit.
- Releasable (can be installed anywhere along the track).
- 100 lb (45 kg) carrying capacity.

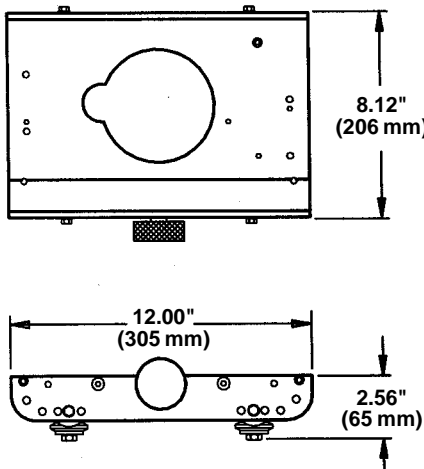

BUG-5910 Split Carriage

Net Weight: 7 lbs. (3.17 kg)
Shipping Weight: 8 lbs. (3.62 kg)

- Mounts a DC IV Drive Unit or a Modular Drive Unit.
- Releasable (can be installed anywhere along the track).
- 100 lb (45 kg) carrying capacity.
- Runs on straight or BRR Ring Rail.



CARRIAGES

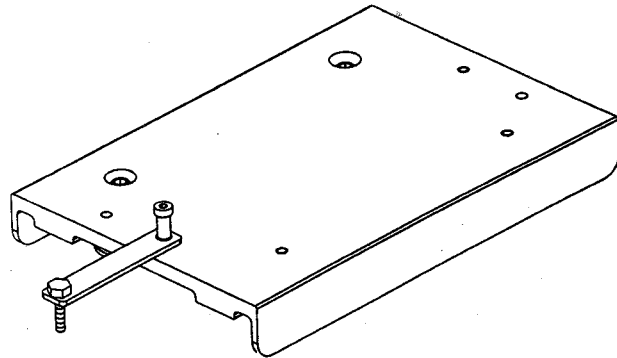
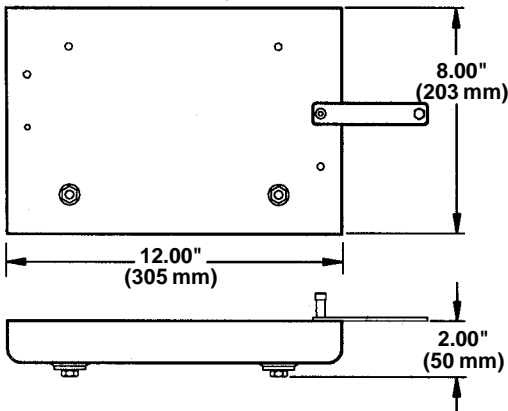

BUG-2205 Carriage Trailer w/Hitch
Net Weight: 6 lbs. (2.72 kg)
Shipping Weight: 8 lbs. (3.62 kg)

- 100 lb (45 kg) carrying capacity
- Used to carry accessories, wire feeder, etc.

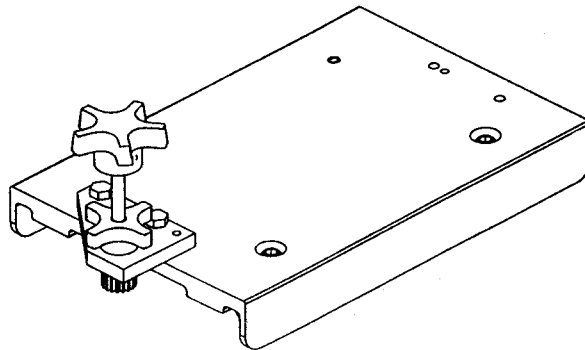
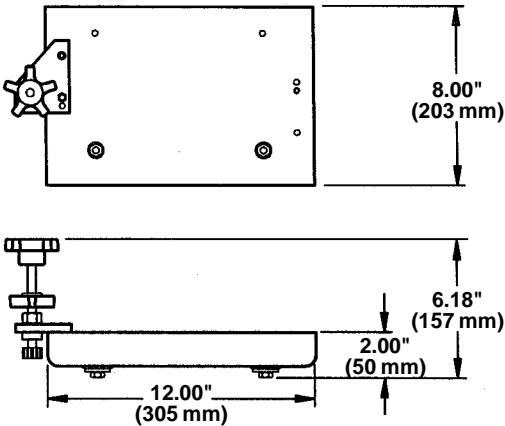

MUG-1140 Spotting Car
Net Weight: 6 lbs. (2.72 kg)
Shipping Weight: 8 lbs. (3.62 kg)

- Knob is used manually to move the carriage along the track.
- Bottom knob locks carriage to a fixed rail position

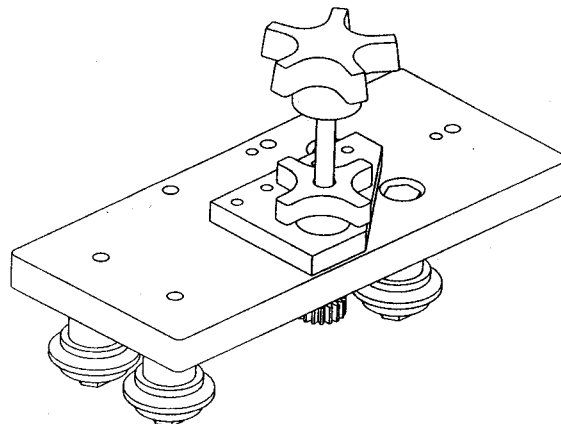
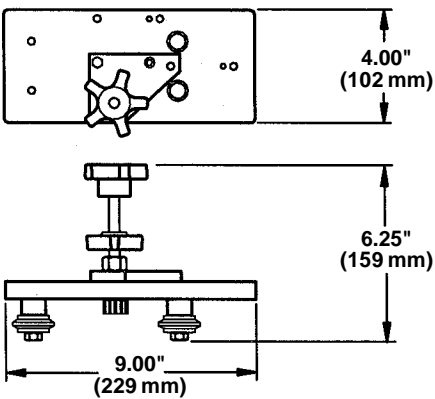

MUG-1148 Torch Spotter
Net Weight: 3 lbs. (1.36 kg)
Shipping Weight: 4 lbs. (1.81 kg)

- Knob is used manually to move the carriage along the track.
- Bottom knob locks carriage to a fixed rail position

A QUALITY PRODUCT FROM BUG-O SYSTEMS • 3001 WEST CARSON STREET • PITTSBURGH, PA USA 15204-1899
 A DIVISION OF WELD TOOLING CORPORATION

© Weld Tooling Corp.

LIT-CARR-BRO-199

ROM 1:16 Litho in U.S.A.